

VTW Series

30W 4:1 Regulated Single & Dual & Triple output



Features

- Ultra Wide 4:1 Input Range
- Full SMD Technology
- 1600 VDC Isolation
- Efficiency up to 91%
- Extended Operating Temperature Range -40 ~ 75°C max.
- Adjustable Output Voltage
- Remote On/Off Control (CTRL)
- Continuous Short Circuit Protection
- Over Current Protection
- Over Voltage Protection
- Over Temperature Protection
- Soft Start



The VTW series is a family of cost effective 30W single & dual & Triple output DC-DC converters. These converters combine nickel-coated copper package in a 2"x1" case with high performance features such as Active Clamp Technology, continuous short circuit protection with automatic restart and tight line / load regulation. Devices are encapsulated using flame retardant resin. Input voltages of 24 and 48 with output voltage of 3.3 , 5 , 5.1, 12, 15, ±5, ±12, ±15Vdc, 3.3/±12, 3.3/±15, 5/±12, 5/±15 . High performance features include high efficiency operation up to 91%.

ALL SPECIFICATIONS ARE TYPICAL AT 25°C, NOMINAL INPUT AND FULL LOAD UNLESS OTHERWISE NOTED.

OUTPUT SPECIFICATIONS																	
Output Voltage Accuracy	Single&Dual: ±1% Triple: ±1% / ±5% (main / auxiliary)																
Output Voltage Adjustability (Single Output Only)	±10%, max																
Maximum Output Current	See table																
Line Regulation	Single&Dual: ±0.5%, max Triple: ±1% / ±5% (main / auxiliary), max																
Load Regulation	Single (0% to 100%): ±0.5%, max Dual (0% to 100%): ±1%, max(balanced load) Triple (10% to 100%): ±1% / ±5% (main / auxiliary), max																
Cross Regulation (1)	Dual: ±5% Triple: ±5%																
Ripple&Noise (2)	Single&Dual : 100mVp-p, max Triple : 50 / 75mVp-p, max (main / auxiliary)																
Over Voltage Protection (Zener diode clamp)	<table border="0"> <tr><td>3.3V output</td><td>3.9V</td></tr> <tr><td>5V output</td><td>6.2V</td></tr> <tr><td>5.1V output</td><td>6.2V</td></tr> <tr><td>12V output</td><td>15V</td></tr> <tr><td>15V output</td><td>18V</td></tr> <tr><td>±5V output</td><td>±6.2V</td></tr> <tr><td>±12V output</td><td>±15V</td></tr> <tr><td>±15V output</td><td>±18V</td></tr> </table>	3.3V output	3.9V	5V output	6.2V	5.1V output	6.2V	12V output	15V	15V output	18V	±5V output	±6.2V	±12V output	±15V	±15V output	±18V
3.3V output	3.9V																
5V output	6.2V																
5.1V output	6.2V																
12V output	15V																
15V output	18V																
±5V output	±6.2V																
±12V output	±15V																
±15V output	±18V																
Over Load Protection	150% of FL, typ																
Short Circuit Protection	Indefinite(hiccup) (Automatic Recovery)																
Temperature Coefficient	±0.02%/°C																
Capacitive Load (3)	See table																
Transient Recovery Time (4)	250us, typ																
Transient Response Deviation (4)	±3%, max																

INPUT SPECIFICATIONS							
Input Voltage Range	See table						
Under Voltage Lockout	<table border="0"> <tr><td>24V Modes</td><td>Module ON / OFF</td><td>8.6Vdc / 7.9Vdc, typ</td></tr> <tr><td>48V Modes</td><td>Module ON / OFF</td><td>17.8Vdc / 16Vdc, typ</td></tr> </table>	24V Modes	Module ON / OFF	8.6Vdc / 7.9Vdc, typ	48V Modes	Module ON / OFF	17.8Vdc / 16Vdc, typ
24V Modes	Module ON / OFF	8.6Vdc / 7.9Vdc, typ					
48V Modes	Module ON / OFF	17.8Vdc / 16Vdc, typ					
Start up Time (Nominal Vin and constant resistive load)	30mS, typ						
Input Filter	Pi Type						
Input Current (No-Load)	See table, max						
Input Current (Full-Load)	See table, typ						
Input Reflected Ripple Current (5)	20mA _{p-p} , typ						
Remote On/Off (CTRL) (6)	<table border="0"> <tr><td>ON:</td><td>3.0 ... 12Vdc or open circuit</td></tr> <tr><td>OFF:</td><td>0 ... 1.2Vdc or Short circuit pin2 and pin 3</td></tr> <tr><td>OFF idle current:</td><td>5 mA, typ</td></tr> </table>	ON:	3.0 ... 12Vdc or open circuit	OFF:	0 ... 1.2Vdc or Short circuit pin2 and pin 3	OFF idle current:	5 mA, typ
ON:	3.0 ... 12Vdc or open circuit						
OFF:	0 ... 1.2Vdc or Short circuit pin2 and pin 3						
OFF idle current:	5 mA, typ						

GENERAL SPECIFICATIONS	
Efficiency	See table, typ
I/O Isolation Voltage (3 sec)	1600Vdc
Input/Output	1600Vdc
Case/Input & Output	1600Vdc
Isolation Resistance	1000 MΩ, min
Isolation Capacitance	1500 pF, typ
Switching frequency	330kHz, typ
Humidity	95% rel H
Reliability Calculated MTBF (MIL-HDBK-217 F)	Single&Dual: >435 khrs Triple: >320 khrs
Safety Standard (designed to meet)	IEC/EN 60950-1

EMC CHARACTERISTICS		
Radiated Emissions	EN55022	CLASS A
Conducted Emissions(7)	EN55022	CLASS A
ESD	EN61000-4-2	Perf. Criteria A
RS	EN61000-4-3	Perf. Criteria A
EFT(8)	EN61000-4-4	Perf. Criteria A
Surge (8)	EN61000-4-5	Perf. Criteria A
CS	EN61000-4-6	Perf. Criteria A
PFMF	EN61000-4-8	Perf. Criteria A

PHYSICAL SPECIFICATIONS	
Case Material	Nickel-coated Copper
Base Material	Non-conductive Black Plastic(UL94V-0 rated)
Pin Material	Ø1.0mm Brass Solder-coated
Potting Material	Epoxy (UL94V-0 rated)
Weight	31.0g
Dimensions	2.00"x1.00"x0.40"

ABSOLUTE SPECIFICATIONS (9)	
These are stress ratings. Exposure of devices to any of these conditions may adversely affect long-term reliability.	
Input Voltage(100mS)	-0.7~50 Vdc
24 Models	-0.7~100 Vdc
48 Models	-0.7~100 Vdc
Soldering Temperature (1.5mm from case 10 sec. Max.)	260°C max.

ENVIRONMENTAL SPECIFICATIONS	
Operating Ambient Temperature	-40°C ~ +75°C(See Derating Curve)
	-40°C ~ +50°C(For 100% load)
Maximum Case Temperature	105°C
Storage Temperature	-40°C ~ +125°C
Over Temperature Protection (Case)	115°C, typ
Cooling	Nature Convection

The information and specifications contained in this data sheet are believed to be correct at time of publication. However, MOTIEN Technologies accepts no responsibility for consequences arising from printing errors or inaccuracies. Specifications are subject to change without notice. No rights under any patent accompany the sale of any such product(s) or information contained herein.

VTW - 30W 4:1 Regulated Single & Dual & Triple output

PART NUMBER STRUCTURE

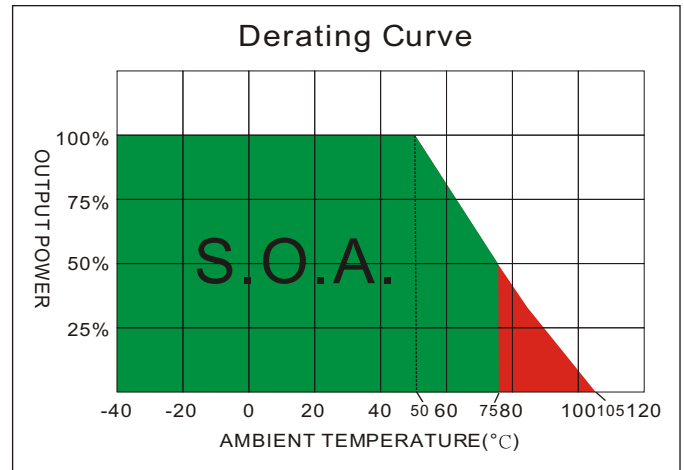
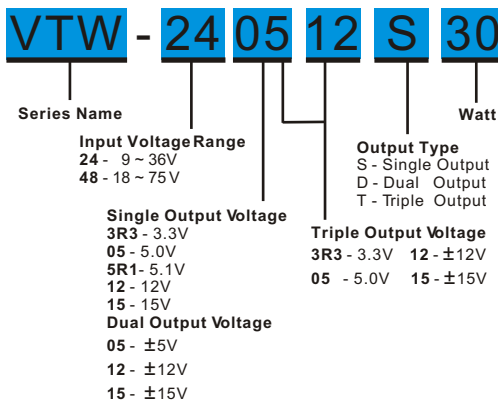

MODEL SELECTION GUIDE

MODEL NUMBER	INPUT Voltage Range (Vdc)	INPUT Current		OUTPUT Voltage (Vdc)	OUTPUT Auxiliary (Vdc)	OUTPUT Current		EFFICIENCY @FL(%)	Capacitor Load(μF)
		No-Load (mA)	Full Load (mA)			Min-Load (mA)	Full Load (mA)		
VTW-243R3S30	9-36	60	1185	3.3		0	7500	89	20000
VTW-2405S30	9-36	100	1420	5		0	6000	91	14000
VTW-245R1S30	9-36	90	1448	5.1		0	6000	91	14000
VTW-2412S30	9-36	30	1436	12		0	2500	90	2000
VTW-2415S30	9-36	30	1420	15		0	2000	91	2000
VTW-483R3S30	18-75	50	593	3.3		0	7500	89	20000
VTW-4805S30	18-75	60	702	5		0	6000	91	14000
VTW-485R1S30	18-75	60	724	5.1		0	6000	91	14000
VTW-4812S30	18-75	30	718	12		0	2500	90	2000
VTW-4815S30	18-75	30	710	15		0	2000	90	2000
VTW-2405D30	9-36	120	1437	±5		0	±3000	90	±3000
VTW-2412D30	9-36	30	1453	±12		0	±1250	89	±1300
VTW-2415D30	9-36	40	1437	±15		0	±1000	89	±1300
VTW-4805D30	18-75	70	710	±5		0	±3000	91	±3000
VTW-4812D30	18-75	30	718	±12		0	±1250	90	±1300
VTW-4815D30	18-75	40	718	±15		0	±1000	90	±1300
VTW-243R312T30	9-36	80	1287	3.3	±12	500 / ±42	5000 / ±420	89	15000 / ±220
VTW-243R315T30	9-36	90	1279	3.3	±15	500 / ±33	5000 / ±330	89	15000 / ±220
VTW-240512T30	9-36	100	1440	5	±12	400 / ±42	4000 / ±420	89	8000 / ±220
VTW-240515T30	9-36	110	1431	5	±15	400 / ±33	4000 / ±330	90	8000 / ±220
VTW-483R312T30	18-75	50	636	3.3	±12	500 / ±42	5000 / ±420	89	15000 / ±220
VTW-483R315T30	18-75	50	640	3.3	±15	500 / ±33	5000 / ±330	89	15000 / ±220
VTW-480512T30	18-75	60	712	5	±12	400 / ±42	4000 / ±420	91	8000 / ±220
VTW-480515T30	18-75	60	707	5	±15	400 / ±33	4000 / ±330	90	8000 / ±220

NOTE

- Dual: One load is 25% to 100% load, the other load is 100% load, the output voltage variable rate is within ±5%.
Triple: Main output 100% load, auxiliary 100%, other auxiliary 25% to 100%.
Auxiliary outputs (+ Aux and -Aux) : main output 100% load, auxiliary 100%, other auxiliary 25% to 100% or main output 25%, auxiliary 25%, other auxiliary 25% to 100%.
- Measured with 20MHz bandwidth and 1.0uF ceramic capacitor.
- Tested by minimal Vin and constant resistive load.
- Tested by normal Vin and 25% load step change (75%-50%-25% of Io).
- Measured Input reflected ripple current with a simulated source inductance of 12uH.
- The remote on/off control pin is referenced to -Vin(pin2).
- The VTW series can meet EN55022 Class A With an external filter in parallel with the input pins.
- An external filter capacitor is required if the module has to meet EN61000-4-4 and EN61000-4-5.
The filter capacitor Motien suggest: Nippon chemi-con KY series, 220uF/100V.
- Exceeding the absolute ratings of the unit could cause damage.
It is not allowed for continuous operating.

The models listed above is just for standard type. If you need the special specification product, please contact our service member by telephone presented in shortform cover or e-mail to : sales@motien.com.tw

Triple Series - TEST CONFIGURATIONS

Input Reflected Ripple Current Test Step

Input reflected ripple current is measured through a source inductor L_{in} (4.7uH) and a source capacitor C_{in} (33uF, ESR<1.0Ω at 100KHz) at nominal input and full load.

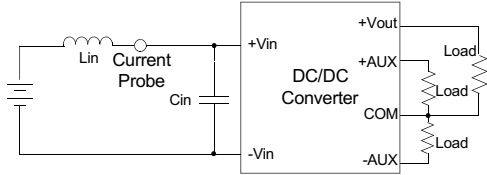

Output Ripple & Noise Measurement Test

Use a capacitor C_{out} (1.0uF) measurement. The Scope measurement bandwidth is 0-20MHz.

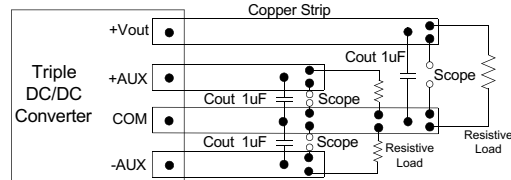

EMI Filter

Input filter components (C_1 , C_3 , L) are used to help meet conducted emissions requirement for the module. These components should be mounted as close as possible to the module; and all leads should be minimized to decrease radiated noise.

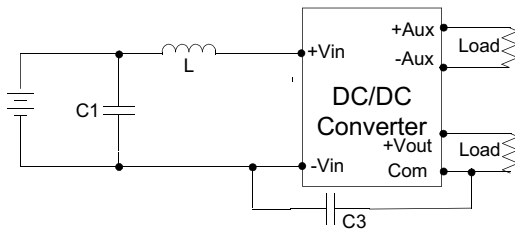

	C1	L	C3
VTW-24XXXXXXXXXX	100uF, 100V	12uH	1206,470PF, 2KV
VTW-48XXXXXXXXXX	100uF, 100V	12uH	1206,470PF, 2KV

Single & Dual Series - TEST CONFIGURATIONS

Input Reflected Ripple Current Test Step

Input reflected ripple current is measured through a source inductor L_{in} (4.7uH) and a source capacitor C_{in} (33uF, ESR<1.0Ω at 100KHz) at nominal input and full load.

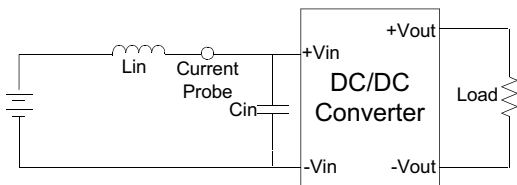

Output Ripple & Noise Measurement Test

Use a capacitor C_{out} (1.0uF) measurement. The Scope measurement bandwidth is 0-20MHz.

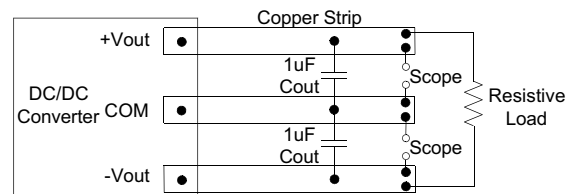

EMI Filter

Input filter components (C_1 , C_3 , L) are used to help meet conducted emissions requirement for the module. These components should be mounted as close as possible to the module; and all leads should be minimized to decrease radiated noise.

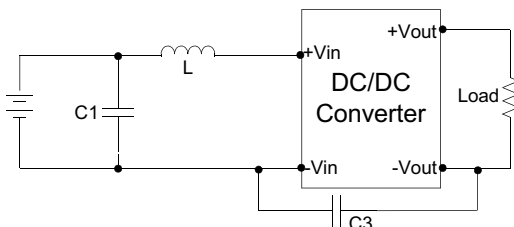

	C1	L	C3
VTW-24XXXXXXXXXX	100uF, 100V	12uH	1206,470PF, 2KV
VTW-48XXXXXXXXXX	100uF, 100V	12uH	1206,470PF, 2KV

ELECTRICAL CHARACTERISTIC CURVES

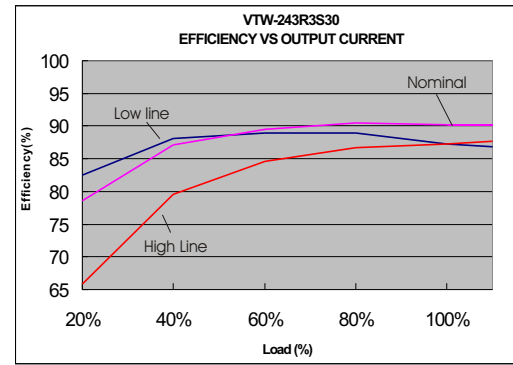
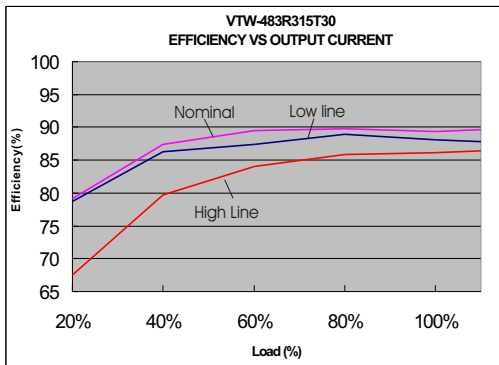
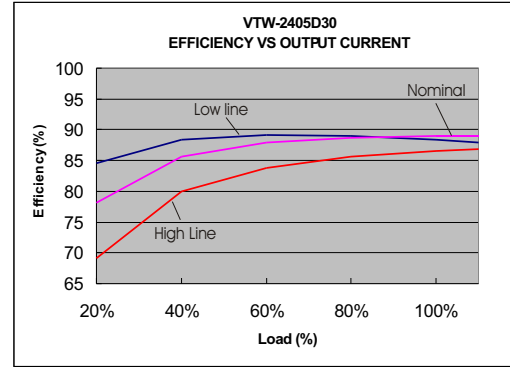
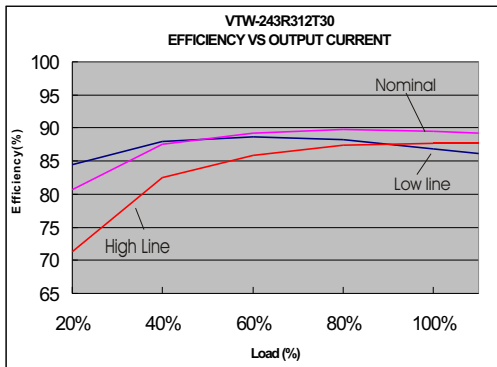

MECHANICAL SPECIFICATIONS

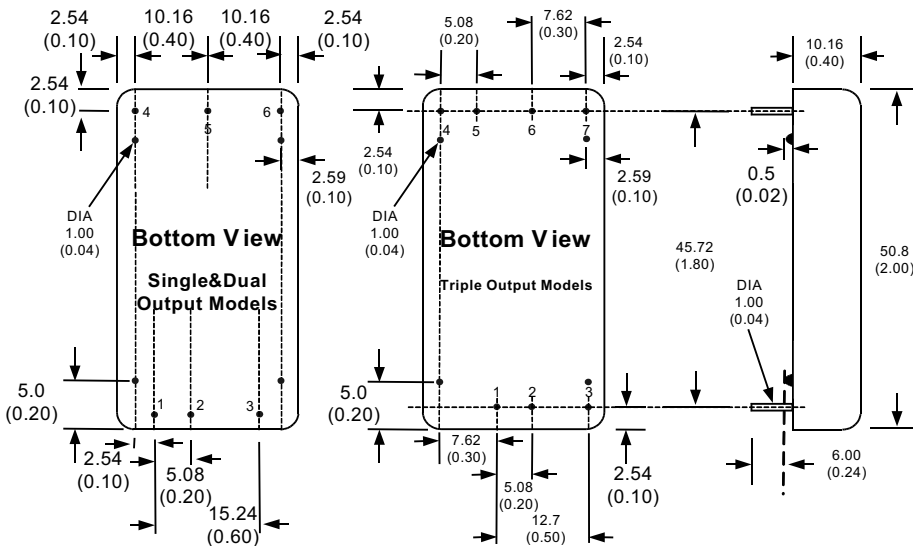

PIN CONNECTIONS			
PIN NUMBER	SINGLE	DUAL	Triple
1	+Vin	+Vin	+Vin
2	-Vin	-Vin	-Vin
3	CTRL	CTRL	CTRL
4	+Vout	+Vout	+Aux
5	-Vout	Com	-Aux
6	Trim	-Vout	Com
7	No pin	No pin	+Vout

EXTERNAL OUTPUT TRIMMING

Output can be externally trimmed by using the method as below. (single output models only)

Rtrim-up

Rtrim-down

- All dimensions are typical in millimeters (inches).
1. Pin diameter: 1.0 ±0.05 (0.04 ±0.002)
 2. Pin pitch and length tolerance: ±0.35 (±0.014)
 3. Case Tolerance: ±0.5 (±0.02)
 4. Stand-off tolerance: ±0.1 (±0.004)